

# MANUFACTURER'S TIPS

## NECESSARY TOOLS:

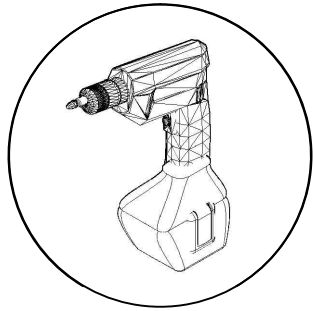

ELECTRIC SCREWDRIVER

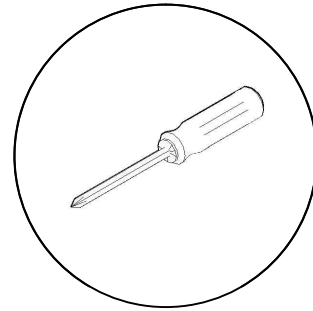

MANUAL SCREWDRIVER

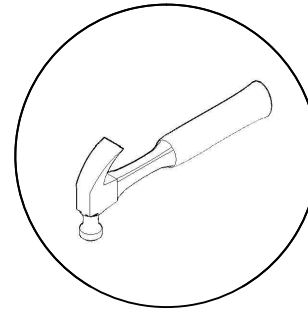

HAMMER

## ASSEMBLY TIME:

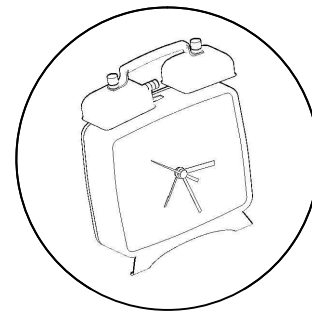

60 MINUTES

## ASSEMBLY TIPS:

- A** - SEPARATE AND IDENTIFY THE PARTS AS PER THE ASSEMBLY INSTRUCTIONS. .
- B** - IF THE UNIT IS TO BE ASSEMBLED LYING DOWN, DO SO WITH IT FACING UPWARDS, RESTING ON THE CARDBOARD. TURN THE UNIT AROUND TO INSTALL THE BACK BOARD.
- C** - REMEMBER, IF THE BACK BOARD IS NOT INSTALLED CORRECTLY, THE UNIT WILL NOT ALIGN PROPERLY.
- D** - FOR A BETTER FINISH, DON'T FORGET TO PUT THE LIDS ON THE SCREWS.

## PRODUCT CARE:

- A** - USE A SLIGHTLY DAMPENED CLOTH TO CLEAN THE UNIT.
- B** - AVOID LEAVING THE UNIT IN THE SUN, AS THIS WILL WEAR OUT THE PAINTWORK.
- C** - DON'T LET THE UNIT COME INTO CONTACT WITH WATER.

ATTENTION: FOLLOW THESE ASSEMBLY INSTRUCTIONS CAREFULLY

## DRESSER VISAGE - 8 DRAWER - VS908EA - ONIX / TERRACOTA

Dimensions: Height: 1.86 - Width: 1.2 - Depth: 0.40

	Fittings	Qty	Code
A	FLAT HEAD SCREW 4 X 40	25	255
B	FLAT SCREW 3.5 X 14	96	252
C	TUBE OF GLUE	01	2783
D	HOLE COVER STICKER onix	38	16325
E	PEG 8 X 30	12	266
F	PEG 6 X 30	16	372
G	MINIFIX PIN	38	2773
H	MINIFIX CAM	38	2774
I	H PROFILE 1200MM GREY	01	16914
J	NAIL 10 X 10	110	263
K	STYLE CURVE	08	15438
L	PLASTIC SOCKET	06	37549
M	NAIL 13 X 15	32	264
N	METALIC SLIDE 350MM	08	424

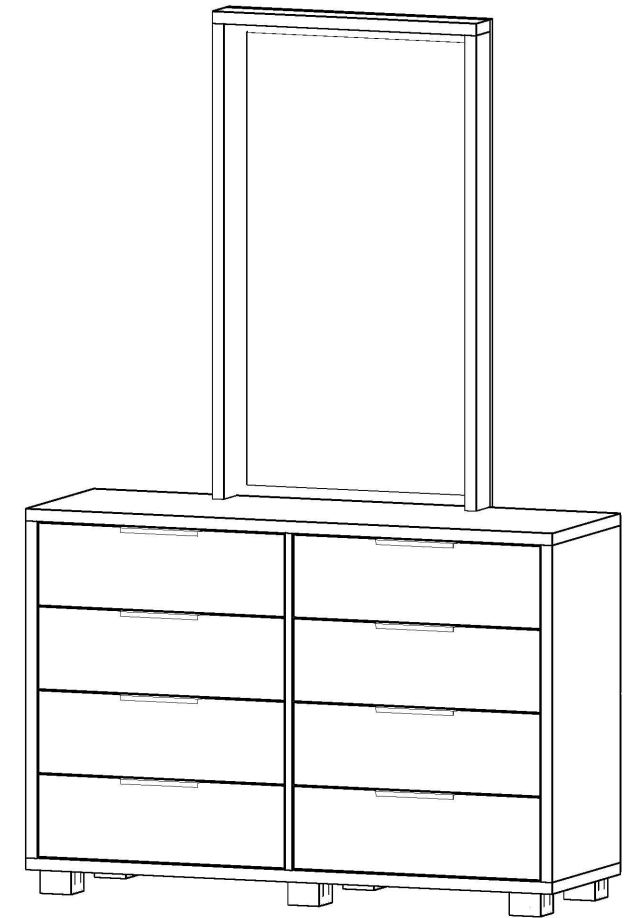

**ATTENTION !!!**  
MIRROR: REMOVE THE PROTECTION OF DOUBLE-SIDED TAPE. AFTER MAKING THE APPLICATION, ALIGNING THE MIRROR THERE ARE 20MM OF THE DRESSING TABLE TOP.

Part	Code	Description	Qty.	Dimension parts :
01	37530	Tophead onix	01	1200X385X25 mm
02	37512	Backboard onix	01	1200X385X25 mm
03	37513	Left sideboard onix	01	720X385X25 mm
04	37514	Right sideboard onix	01	720X385X25 mm
05	37515	Division onix	01	720X385X15 mm
06	37518	Smaller frame onix	01	600X70X25 mm
07	37517	Larger frame onix	02	1015X70X25 mm
08	37516	Panel with mirror terracota	01	1250X600X15 mm
09	37529	Draw terracota	08	560X175X15 mm
10	37520	onix draw sideboard	16	365X120X15 mm
11	37521	onix draw rearboard	08	511X97X15 mm
12	37522	Draw bottom stylized Primavera	08	541X370X03 mm
13	37523	Bottomboard chest	02	1190X377X03 mm
14	37528	Set of fittings		

ATTENTION: FOLLOW THESE ASSEMBLY INSTRUCTIONS CAREFULLY

### STAGE 1 ASSEMBLY

**FITTINGS:** FOR EASE AND SPEED, INSERT THE CORRESPONDING FITTINGS INTO THE SIDES (03 AND 04), AS WELL AS THE DIVISION (05). AS THE DRAWING BELOW.

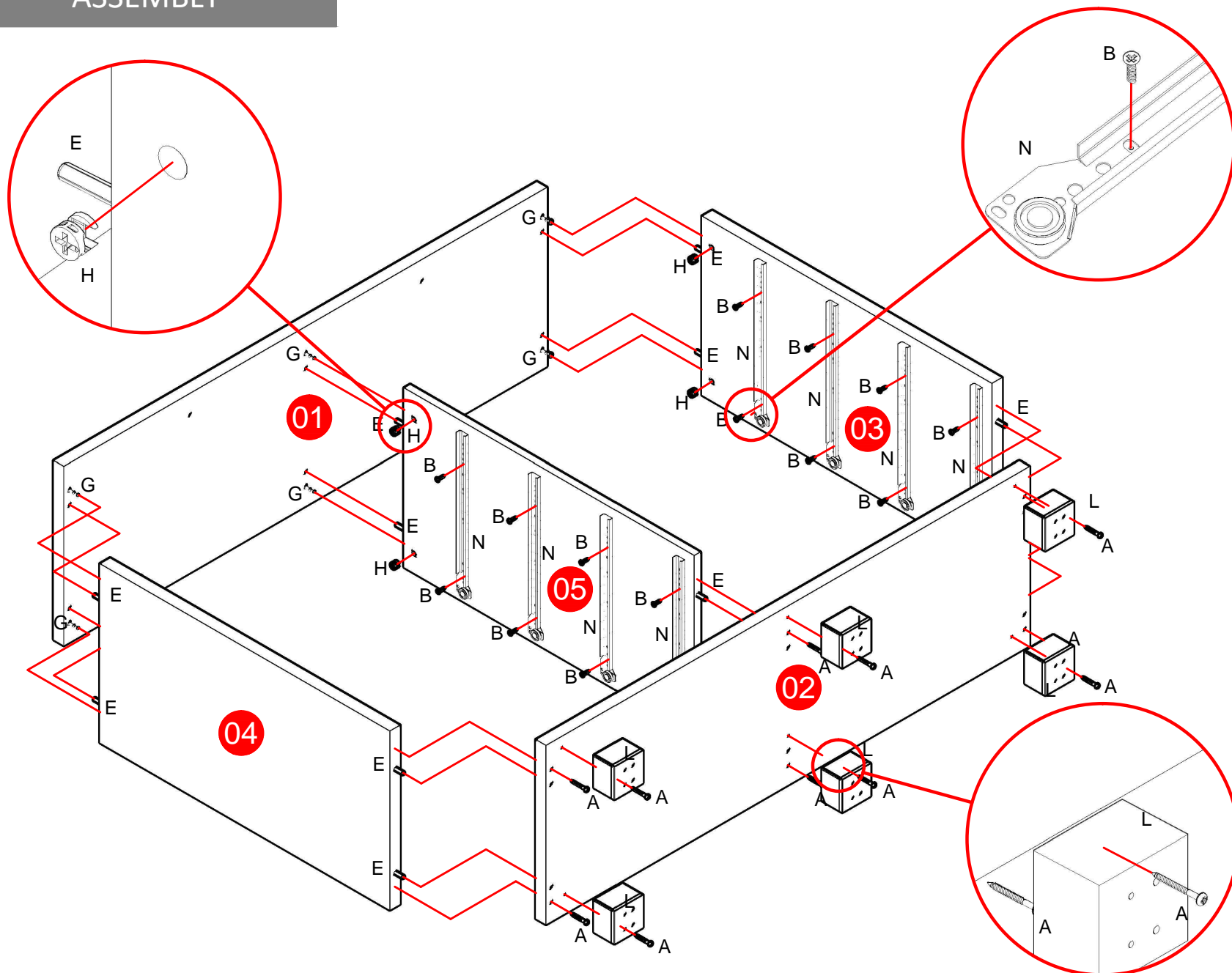

### STAGE 3 NAILING IN THE BACKBOARD

**REMEMBER:** IF THE BACK BOARD IS NOT INSTALLED CORRECTLY, THE UNIT WILL NOT ALIGN PROPERLY. **IMPORTANT:** PLACE THE 10X10 NAILS (J) AT A DISTANCE OF EVERY 10 CM.

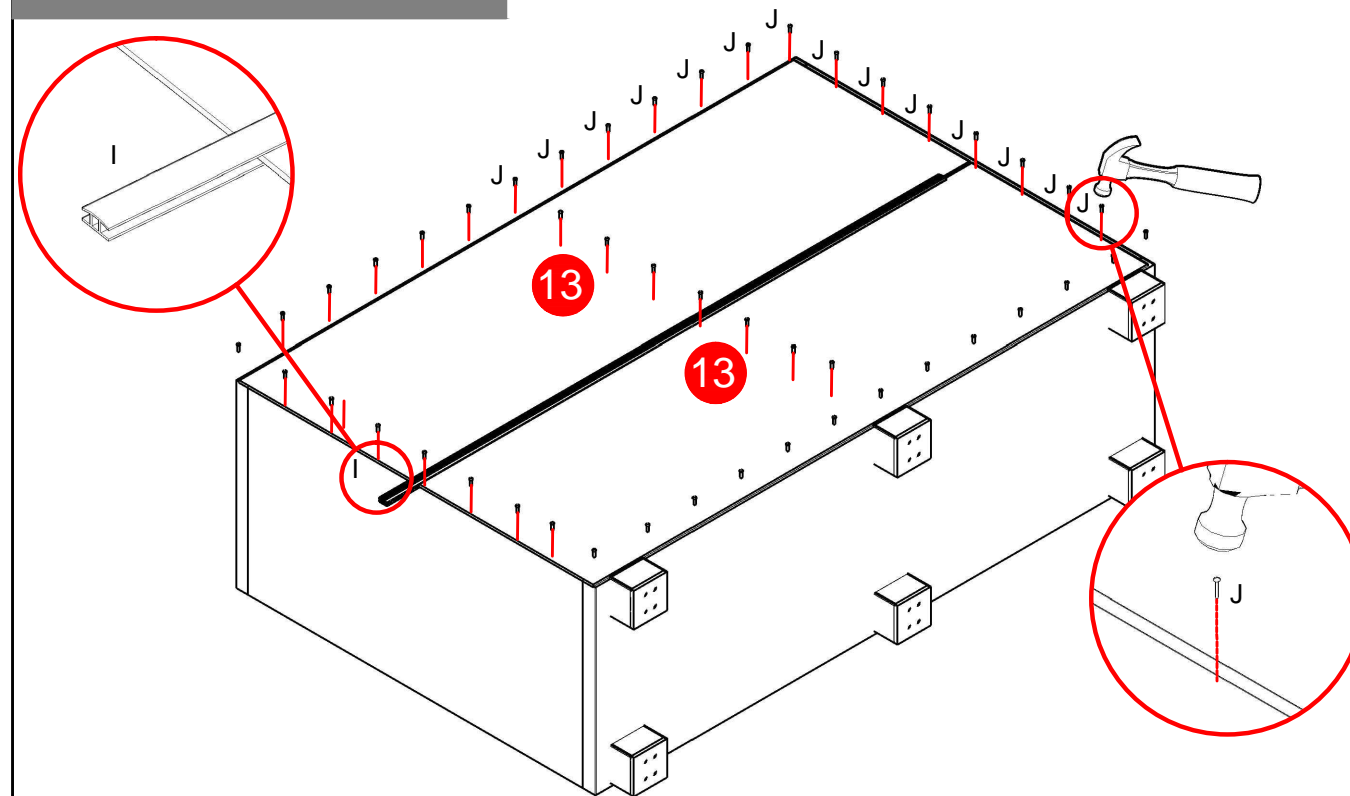

### STAGE 4 MIRROR PANEL

**PANEL:** ASSEMBLE THE PANEL (08) AND ITS FRAMES (06) AND (07). NEXT, ATTACH THE PANEL TO THE BACK OF THE UNIT, UNDER THE TOPHEAD (01), USING THE 4X40 SCREWS (A) AND RESPECTING THE DISTANCE ILLUSTRATED BELOW.

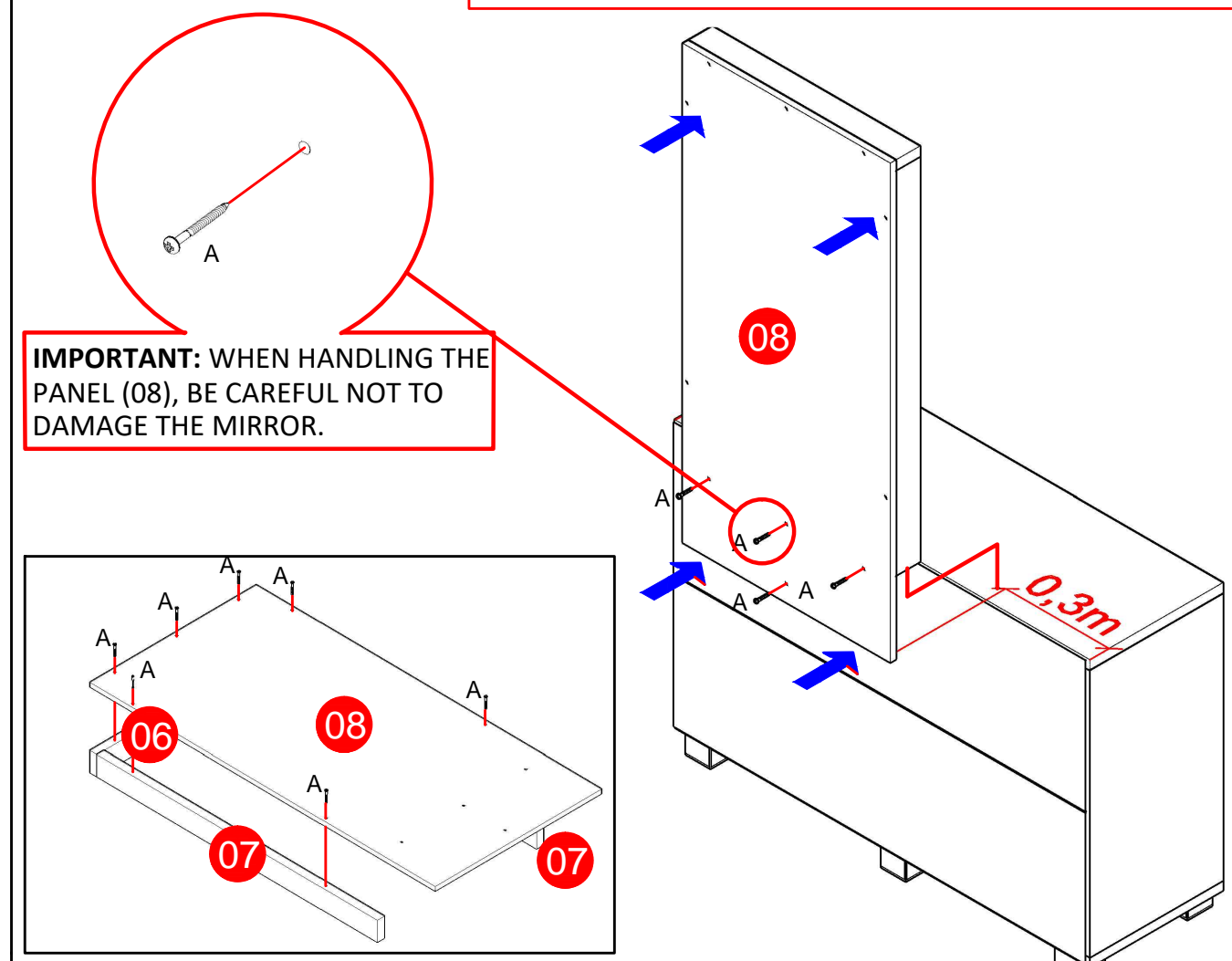

### STAGE 2 DRAWERS

