

## FITTINGS

Cód	Image	Code	Description	Qty
A		6544	FLAT HEAD SCREW 3,5 x 40	43
A.1		8485	PEG 6 x 40	1
C		252	FLAT HEAD SCREW 3,5 x 14	161
C.3		257	20 x 15 FOOT SOCKET	6
C.4		18246	H 2060MM PROFILE GREY	2
E.1		260	4 HOLE ANGLE BRACKET	4
F.1		372	PEG 6 x 30	24
G.4		7284	DOOR BRAKE	4
H.3		480	OBLONG CLOTHES RAIL SUPPORT	4
H.4		15727	350MM TELESCOPIC SLIDE	2
J		3966	FLAT HEAD SCREW 3,5 x 30	2
J.2		15439	POINT HANDLE	2
J.3		1388	SHELF SUPPORT	8
K.1		39090	CLOTHES RAIL 946MM	1
K.1		39091	CLOTHES RAIL 410MM	1
L		254	FLAT HEAD SCREW 4 x 25	12
L.4		7284	LOWER ROLLERS	4
M.4		39084	LOWER TRACK 1920MM	1
O		4627	FLANGED SCREW 3,5 x 12	10
P.1		263	NAIL 10X10	149
Q.1		264	NAIL 13 x 15	6
Q.2		10067	H 400MM PROFILE GREY	1
R		2773	MINIFIX PIN	8
R.4		39133	ANTI-WARP	2
S		2774	MINIFIX CAM	8
S.4		39724	HOLE COVER STICKER NOCE	23
T.4		38814	HANDLE PROFILE 4062MMN 1999MM	2
V.1		481	HEADBOARD SUPPORT	5
X.1		306	ATTACKMENT	14
X.3		39089	UPPER TRACK 1920MM	1
Y		7047	UNITING PLATE	16
Y.3		7284	UPPER GUIDE WHEELS	4
Z		7284	FLANGED SCREW 4 x 12	24

ATTENTION: FOLLOW THESE ASSEMBLY INSTRUCTIONS CAREFULLY

## WARDROBE VALETTA 2D/2D WITH MIRROR - VS6229ED - NOCE

Dimensions: Height: 2190 - Width: 2000 - Depth: 560

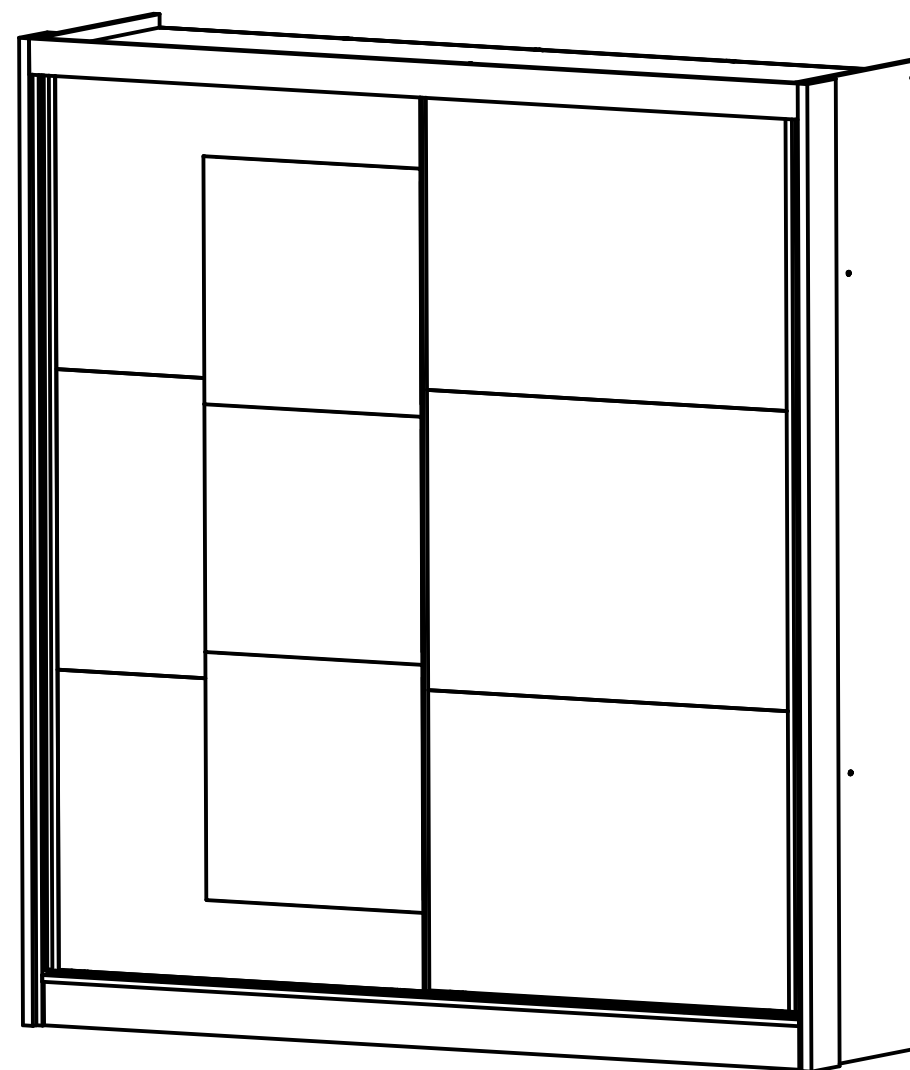

### ASSEMBLY TIPS

- A - SEPARATE AND IDENTIFY THE PARTS AS PER THE ASSEMBLY INSTRUCTIONS..
- B - IF THE UNIT IS TO BE ASSEMBLED LYING DOWN, DO SO WITH IT FACING UPWARDS, RESTING ON THE CARDBOARD. TURN THE UNIT AROUND TO INSTALL THE BACK BOARD.
- C - REMEMBER, IF THE BACK BOARD IS NOT INSTALLED CORRECTLY, THE UNIT WILL NOT ALIGN PROPERLY.
- D - FOR A BETTER FINISH, DON'T FORGET TO PUT THE LIDS ON THE SCREWS.

ATTENTION: FOLLOW THESE ASSEMBLY INSTRUCTIONS CAREFULLY

## STAGE 1 ASSEMBLY

**IMPORTANT:** TO SPEED UP THE ASSEMBLY PROCESS, START BY SEPARATING AND IDENTIFYING THE PARTS, THIS WAY THE PROCESS WILL BE QUICKER AND EASIER.

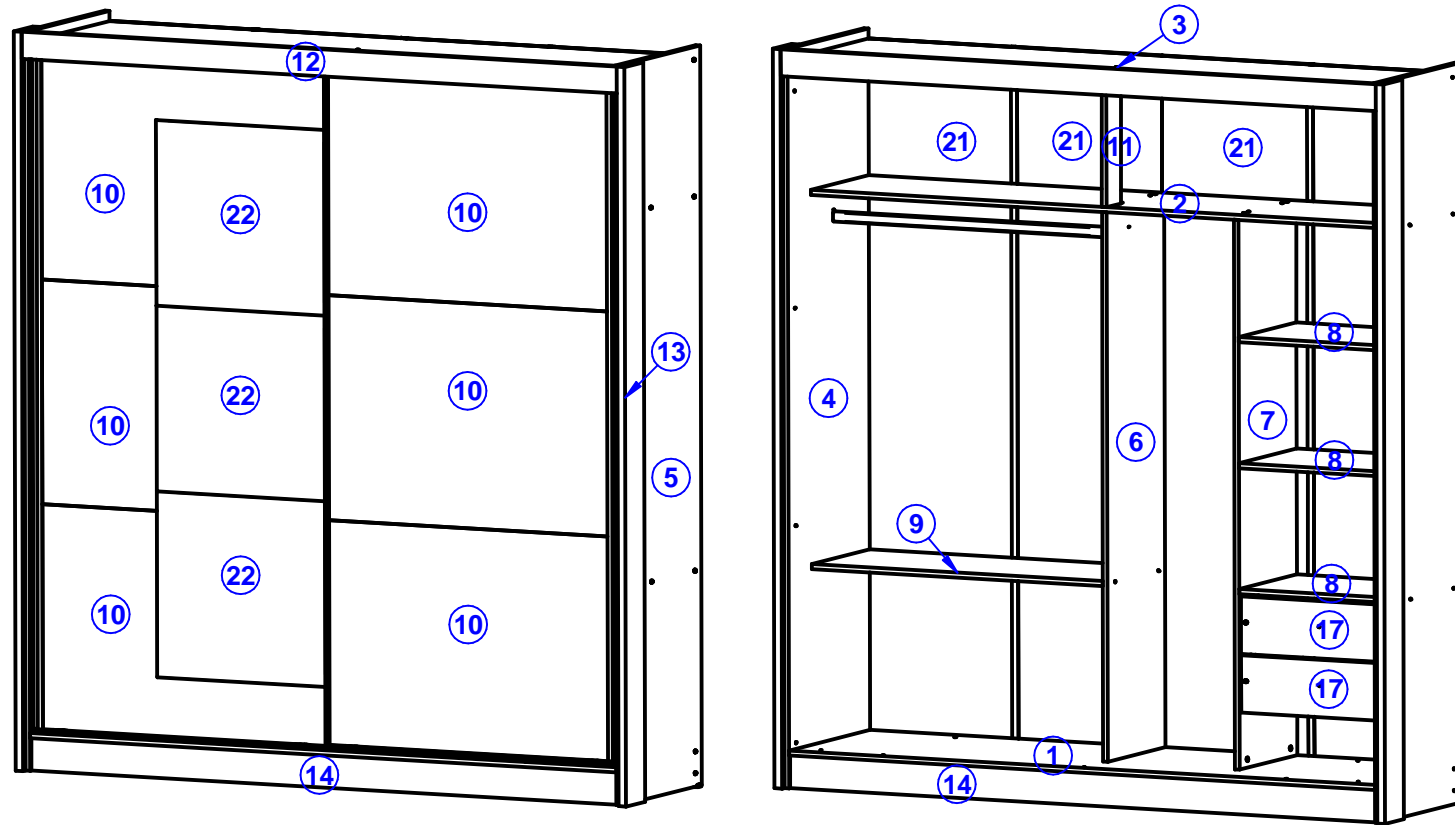

REF	CÓD	DESCRIPTION	QTY	DIMENSIONS
1	38794	LOWER SUPPORT NOCE	1	1920x540x15
2	38796	CENTRAL SUPPORT NOCE	1	1920x385x15
3	38795	UPPER TOP NOCE	1	1920x540x15
4	38792	LEFT SIDEBOARD NOCE	1	2190x540x15
5	38793	RIGHT SIDEBOARD NOCE	1	2190x540x15
6	39075	CENTRAL PARTING NOCE	1	1628x385x15
7	38802	RIGHT PARTING NOCE	1	1628x385x15
8	38803	SMALLER SHELF NOCE	3	520x385x15
9	38809	LARGER SHELF NOCE	1	953x385x15
10	38813	DOOR WHITE	6	945x666x15
11	38801	INTERNAL PILLAR NOCE	1	390x97x15
12	38800	FRONT TOPBOARD WHITE	1	1950x80x15
13	38820	VERTICAL FRAME NOCE	2	2190x126x25
14	38798	FRONT BASEBOARD NOCE	1	1920x97x15
15	38799	REAR BASEBOARD	1	1920x97x15
16	39081	REINFORCEMENT	1	465x97x15
17	38804	INTERNAL DRAW NOCE	2	512x170x15
18	38805	DRAW SIDEBOARD NOCE	4	350x145x15
19	38806	DRAW BACKBOARD NOCE	2	465x97x15
20	38808	DRAW BASEBOARD STYLIZED WHITE	2	495x355x3
21	38811	BACKBOARD CLOSET STYLIZED WHITE	4	2063x482x3
22	2125	MIRROR 550x550 (DUBAI)	3	550x550x3

## STAGE 7 INSERTING THE DOORS

**DOORS:** ATTACH THE RIGHT-SIDE DOOR TO THE BACK RAIL GUIDES (M.4 AND R.3). THEN DO THE SAME WITH THE LEFT-SIDE DOOR, ATTACHING IT TO THE FRONT GUIDES.

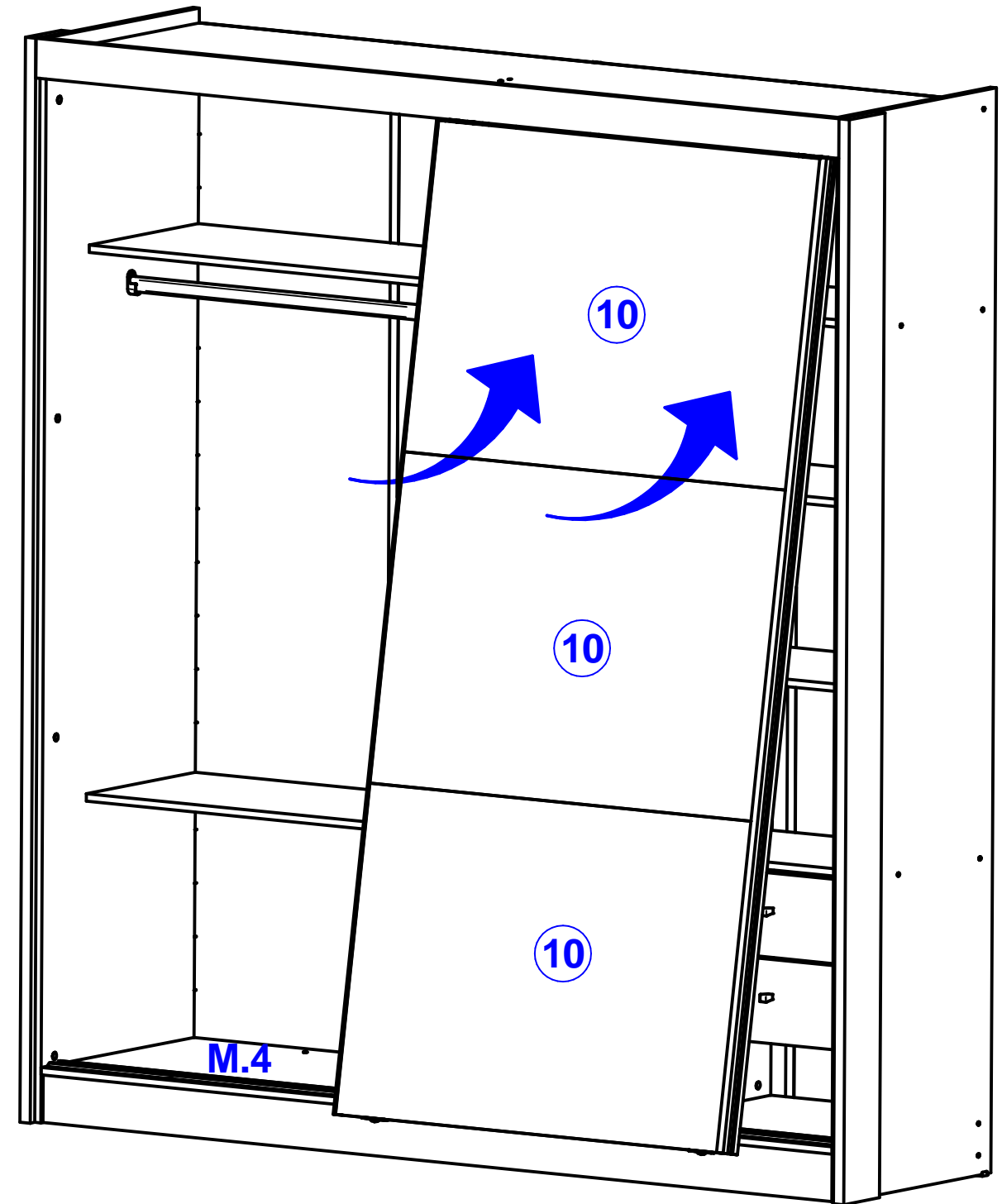

**MIRRORS:** TO FIT THE MIRRORS (22), REMOVE THE DOUBLE-SIDED TAPE AND PRESS THEM ON TO THE DOORS, APPLYING PRESSURE FROM THE CENTER TO THE EDGES.

# STAGE 1 ASSEMBLY

**BASE:** BEING ASSEMBLY BY ATTACHING THE SIDEBOARDS (4 AND 5) AND THE DIVISIONS (6 AND 7) TO THE BASE WITH SCREWS (A). NEXT ATTACH THE SHELVES (8 AND 9), THE MID SUPPORT (2) WITH THE PILLAR (11) ALREADY ATTACHED, AND THE UPPER SUPPORT WITH THE LINING (12) ALREADY ATTACHED. FINALLY, ATTACH THE FRAMES (13) WITH SCREWS (L).

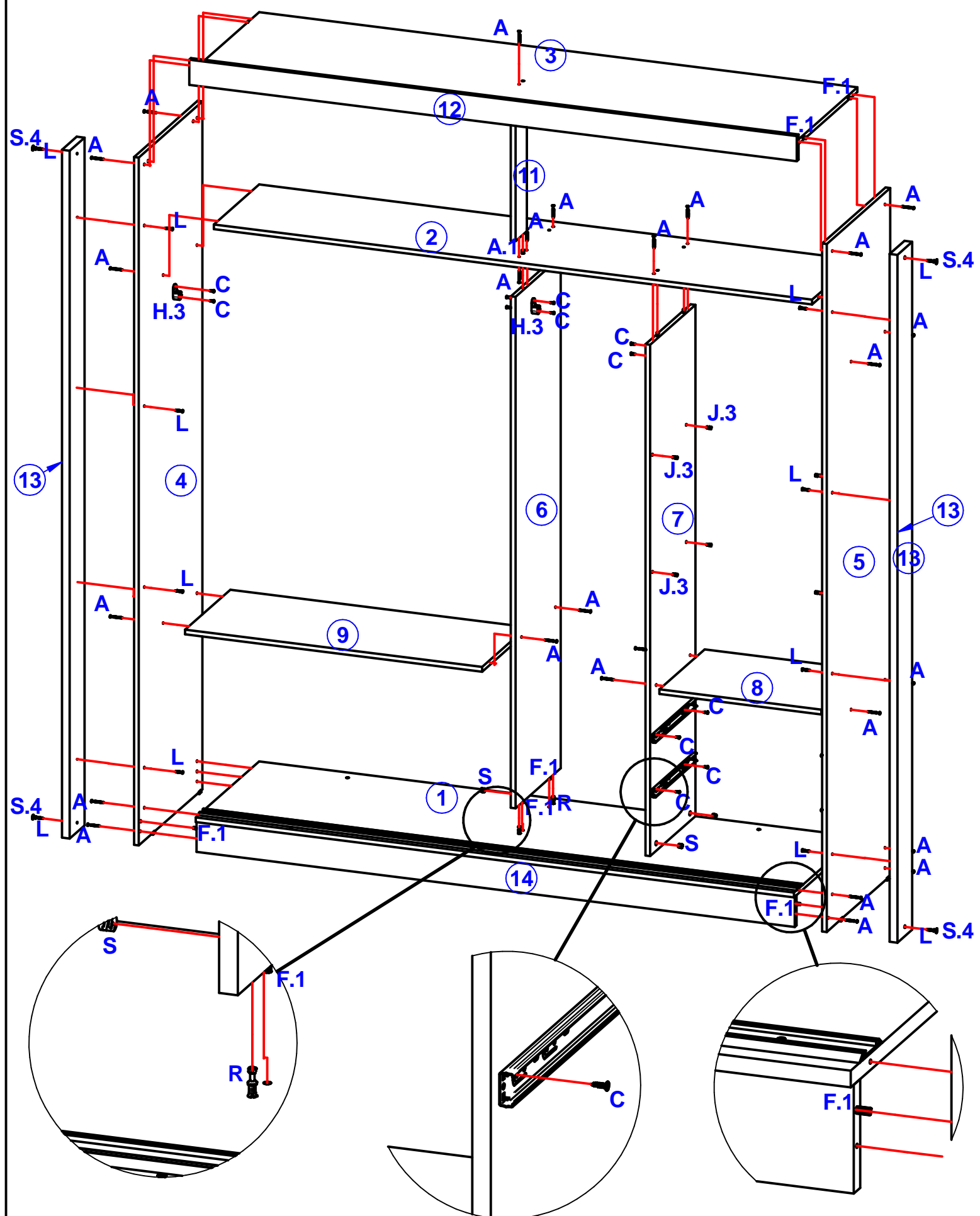

# STAGE 4 BACKBOARDS

**BACKBOARD:** NAIL THE BACKBOARDS (21) WITH 10 X 10 NAILS (P.1) AT 10 CM INTERVALS. PLACE THE BOARDS ONE AFTER THE OTHER. REMEMBER: IF THE BACKBOARDS ARE NOT INSTALLED CORRECTLY, THE UNIT WILL NOT ALIGN PROPERLY.

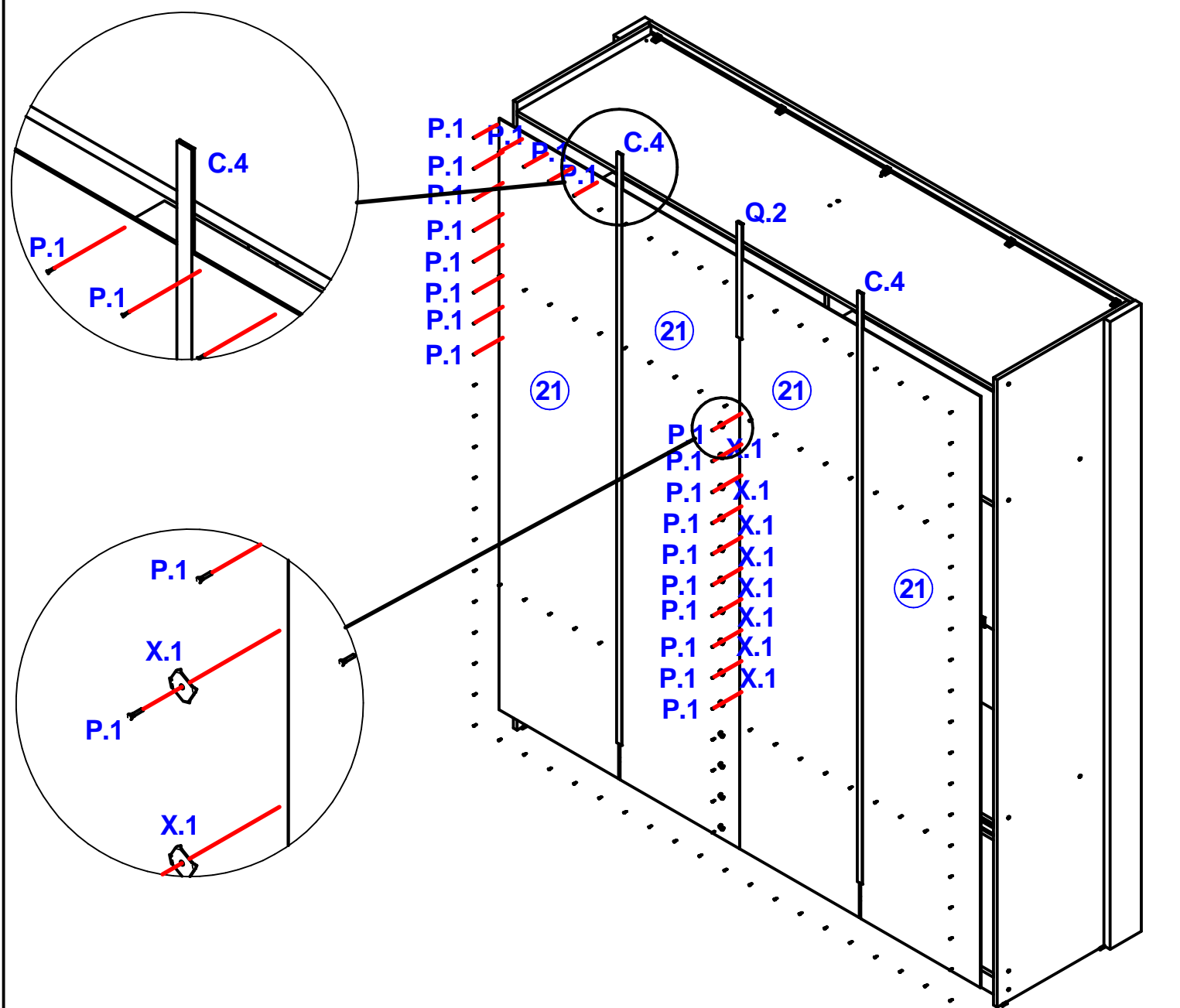

# STAGE 5 DRAWERS

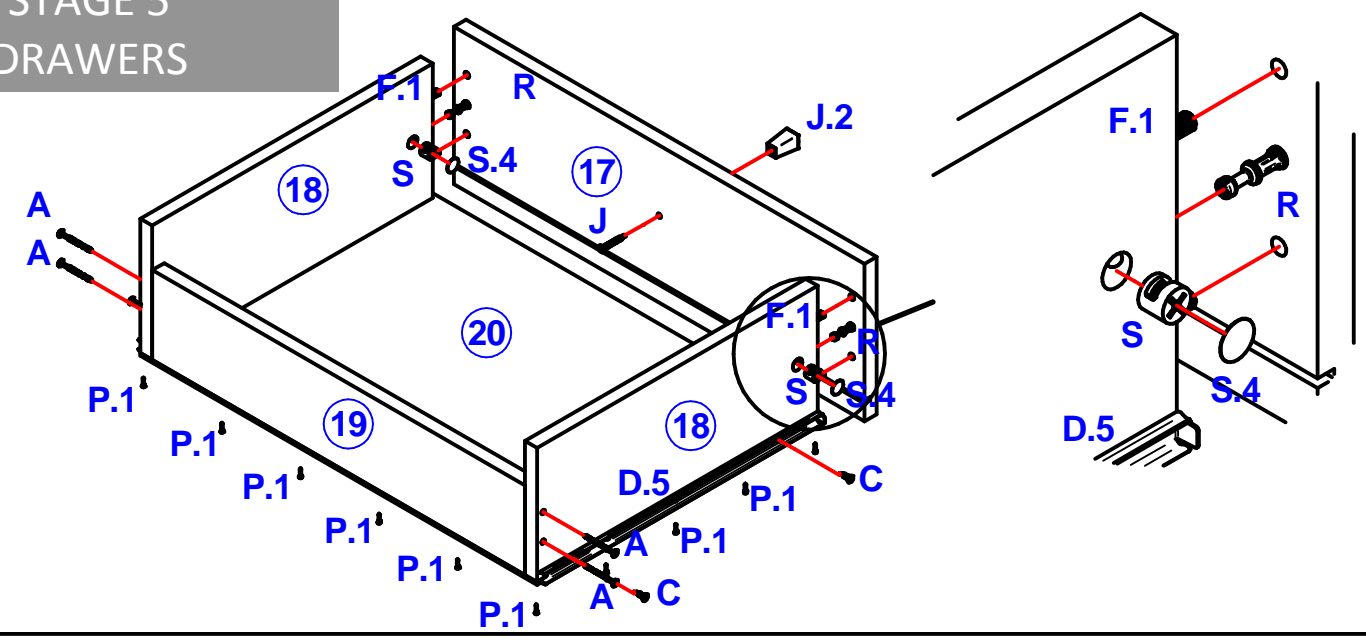

STAGE 6  
DOORS

**PROFILE HANDLE:** WITH THE DOOR (10) LAYING DOWN, INSERT THE HANDLE PROFILE (T.4) SO IT FITS. NEXT, FIX IT WITH SCREWS (O). NEXT, REPEAT THE SAME PROCESS WITH THE STRETCHING PROFILE (R.4) ON THE OPPOSITE SIDE OF THE DOOR.

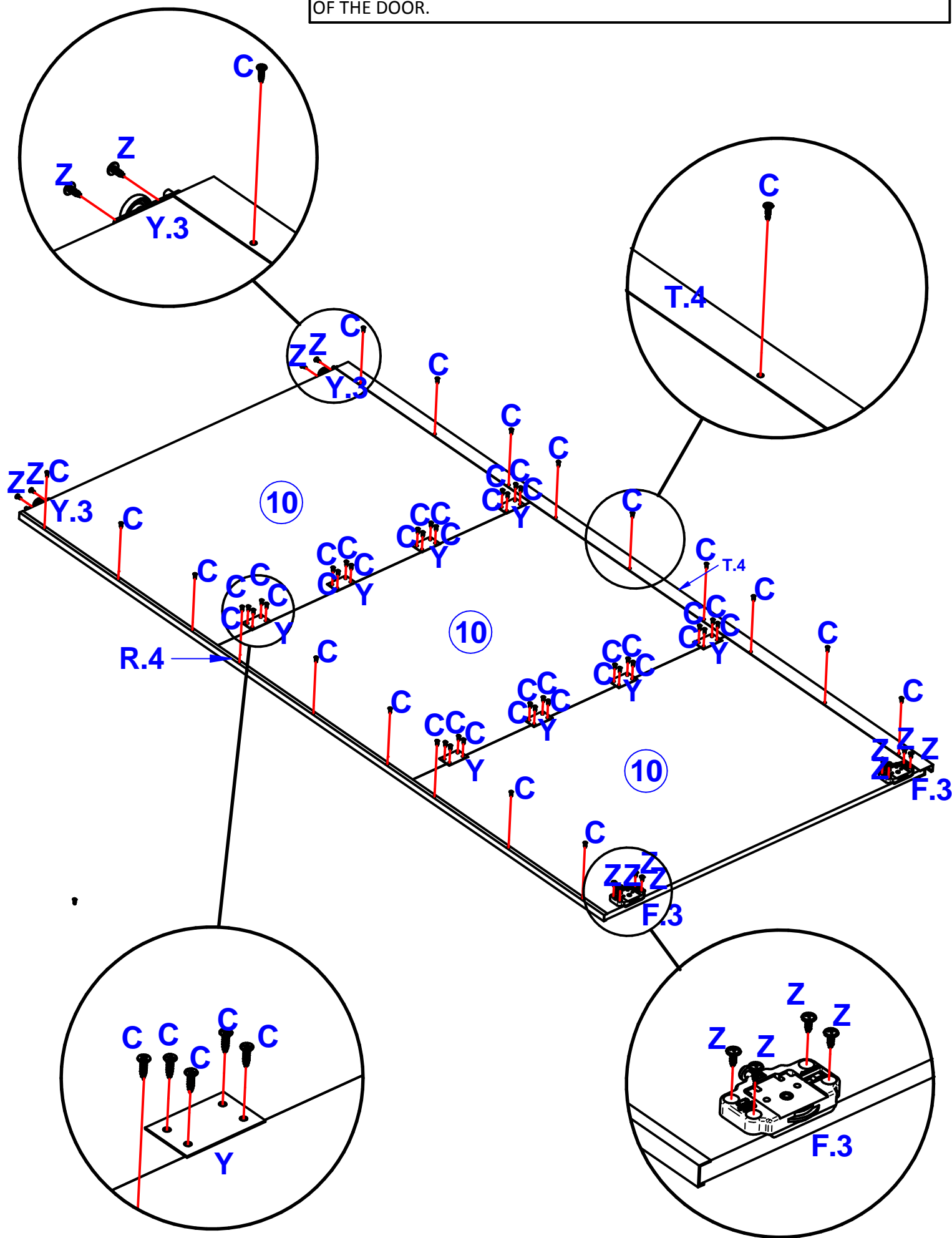

STAGE 2  
BASEBOARD

**BASEBOARD:** IDENTIFY THE PARTS THEN BEGIN ASSEMBLY, ATTACHING THE BASEBOARDS (14 AND 15) AND THE SUPPORT BASEBOARD (16) WITH SCREWS (A). NEXT, TURN THE BASE AROUND AND ATTACH THE MINIFIXES (R) AND THE RAIL (M.4) WITH SCREWS (C).

