

















FITTINGS

| Cód | Image | Code | Description | Qty |
|------|---|-------|--------------------------------------|-----|
| K.3 |  | 2969 | BEAM SUPPORT | 10 |
| S.4 |  | 39724 | HOLE COVER STICKER NOCE | 8 |
| A |  | 6544 | FLAT HEAD SCREW 3,5 x 40 | 16 |
| C |  | 252 | FLAT HEAD SCREW 3,5 x 14 | 68 |
| C.1 |  | 266 | PEG 8 x 30 | 30 |
| CA.3 |  | 4007 | ANGLE BRACKET 30 x 40 | 4 |
| D |  | 2677 | PAN HEAD SCREW 4,5 x 50 | 10 |
| D.1 |  | 39223 | PEG 12 X 30 | 4 |
| I |  | 4993 | FLAT HEAD SCREW 1/4 x 70 | 4 |
| L |  | 254 | FLAT HEAD SCREW 4 x 25 | 24 |
| Q.1 |  | 264 | NAIL 13 x 15 | 65 |
| Q.4 |  | 36862 | FIXED SHOES 25 X 11 | 8 |
| R |  | 2773 | MINIFIX PIN | 14 |
| S |  | 2774 | MINIFIX CAM | 14 |
| U.3 |  | 8816 | PLASTIC CORNER WITH LID 20 X 20 X 42 | 12 |
| Y |  | 7047 | UNITING PLATE | 5 |
| Y.2 |  | 1689 | HALF MOON NUT | 4 |

ASSEMBLY TIPS

- A - SEPARATE AND IDENTIFY THE PARTS AS PER THE ASSEMBLY INSTRUCTIONS..
- B - IF THE UNIT IS TO BE ASSEMBLED LYING DOWN, DO SO WITH IT FACING UPWARDS, RESTING ON THE CARDBOARD. TURN THE UNIT AROUND TO INSTALL THE BACK BOARD.
- C - REMEMBER, IF THE BACK BOARD IS NOT INSTALLED CORRECTLY, THE UNIT WILL NOT ALIGN PROPERLY.
- D - FOR A BETTER FINISH, DON'T FORGET TO PUT THE LIDS ON THE SCREWS.

ATTENTION: FOLLOW THESE ASSEMBLY INSTRUCTIONS CAREFULLY

DOUBLE BED - VALLETTA 1800MM - VS6129D - WHITE/NOCE

Dimensions: Height: 1085 - Width: 1902 - Depth: 2162

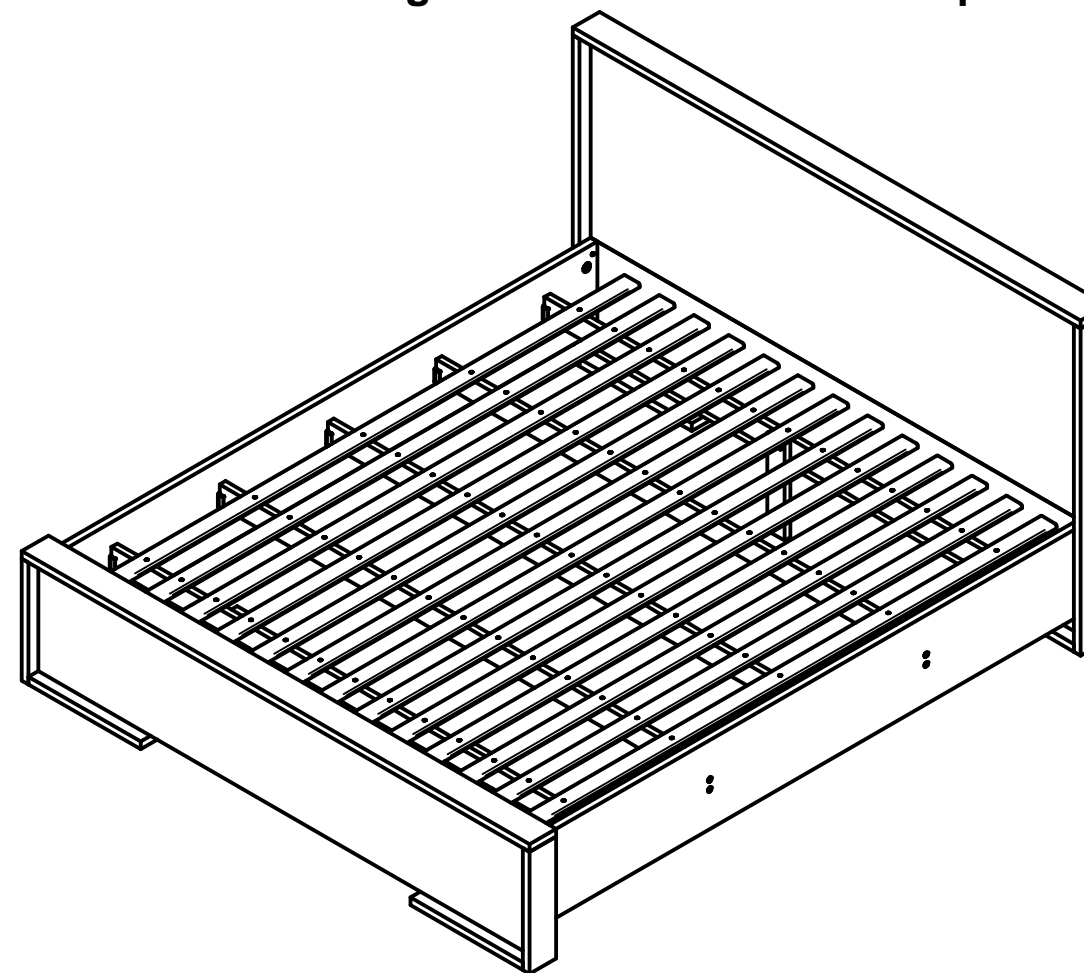

| REF | CÓD | DESCRIPTION | QTY | DIMENSIONS |
|-----|-------|------------------------------|-----|-------------|
| 1 | 38783 | FRONT FEET WHITE | 1 | 1850x370x25 |
| 2 | 38791 | HEADBOARD BOTTOM PANEL WHITE | 1 | 1850x370x15 |
| 3 | 38788 | LARGE HEADBOARD PANEL WHITE | 1 | 1850x665x15 |
| 4 | 38786 | BED BEAM NOCE | 2 | 2042x288x25 |
| 5 | 38790 | HEADBOARD FRAME NOCE | 2 | 1900x100x25 |
| 6 | 38785 | SMALLER VERTICAL FOOT NOCE | 2 | 395x100x25 |
| 7 | 38789 | LARGER VERTICAL FOOT NOCE | 2 | 1060x100x25 |
| 8 | 38787 | BOTTOM BASE NOCE | 4 | 420x100x25 |
| 9 | 39078 | 5 FOOT REINFORCEMENT PINUS | 3 | 317x65x22 |
| 10 | 10950 | CROSS SUPPORT | 5 | 1795x70x22 |
| 11 | 10948 | BEAM | 13 | 1950x60x10 |

ATTENTION: FOLLOW THESE ASSEMBLY INSTRUCTIONS CAREFULLY

**STAGE 1
HEADBOARD**

HEADBOARD: BEING BY JOINGIN PARTS 2 AND 3 TO PART 7 USING THE HARDWARE (R – S – C.1). THEN JOIN PARTS 2 AND 3 TOGETHER USING THE HARDWARE (Y – C). ATTACH PART 8 TO PARTS 2 AND 7, USE THE HARDWARE (C.1 – Q.4 – A – T.3 - C). FINALLY, ATTACH PART 5 TO PARTS 3 AND 7, USE THE HARDWARE (C.1 - C – T.3).

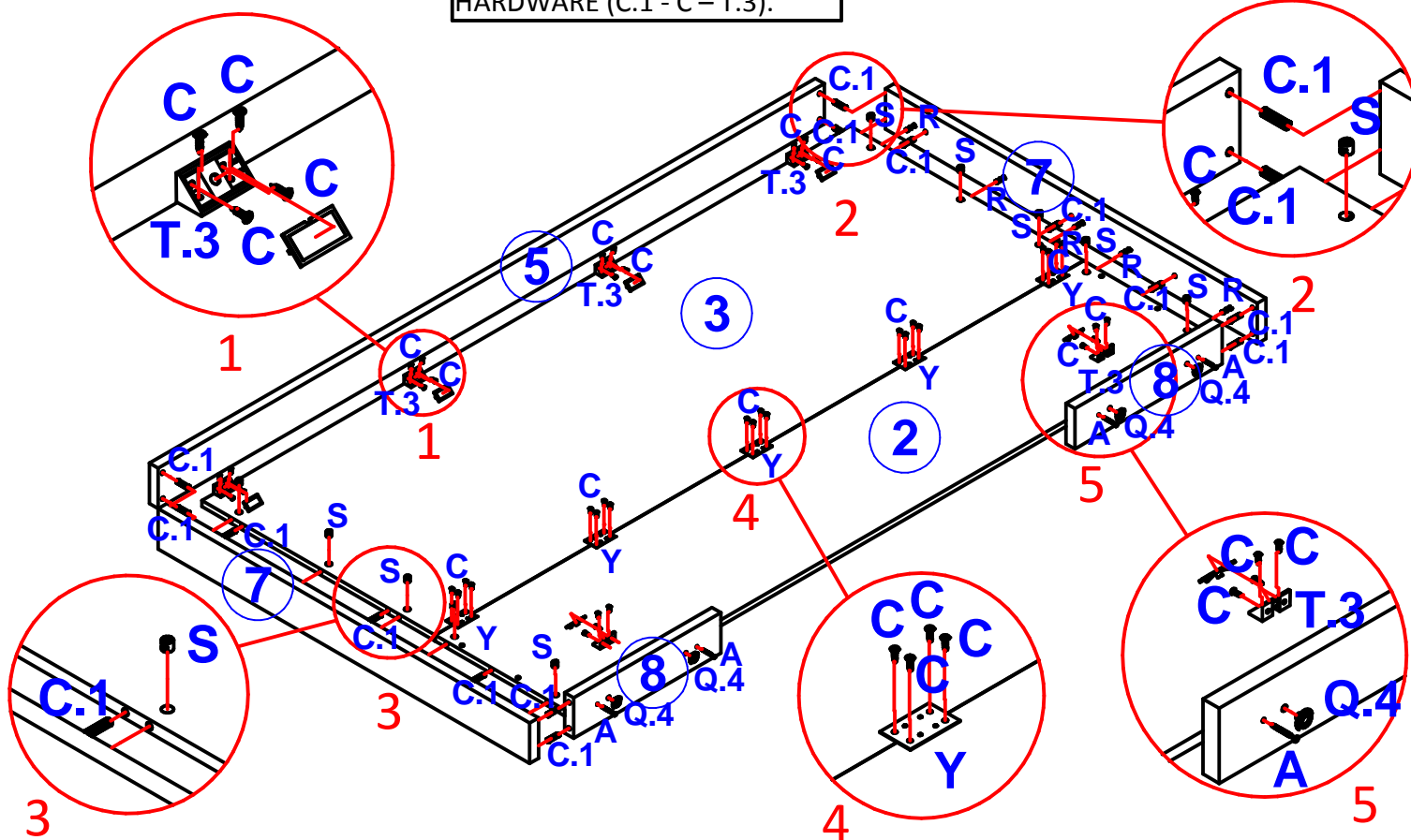

**STAGE 3
ASSEMBLY**

ATTACH THE HARDWARE (K.3) TO THE PARTS (4), THEN JOIN THE PARTS (4) TO THE HEADBOARD (2), USE THE HARDWARE (C.1 – Y.2 - I – A). FOR THE NEXT STEP, ATTACH THE PARTS (4) TO THE FOOTBOARD (1), USE THE HARDWARE (CA.3 – D.1 – L – A).

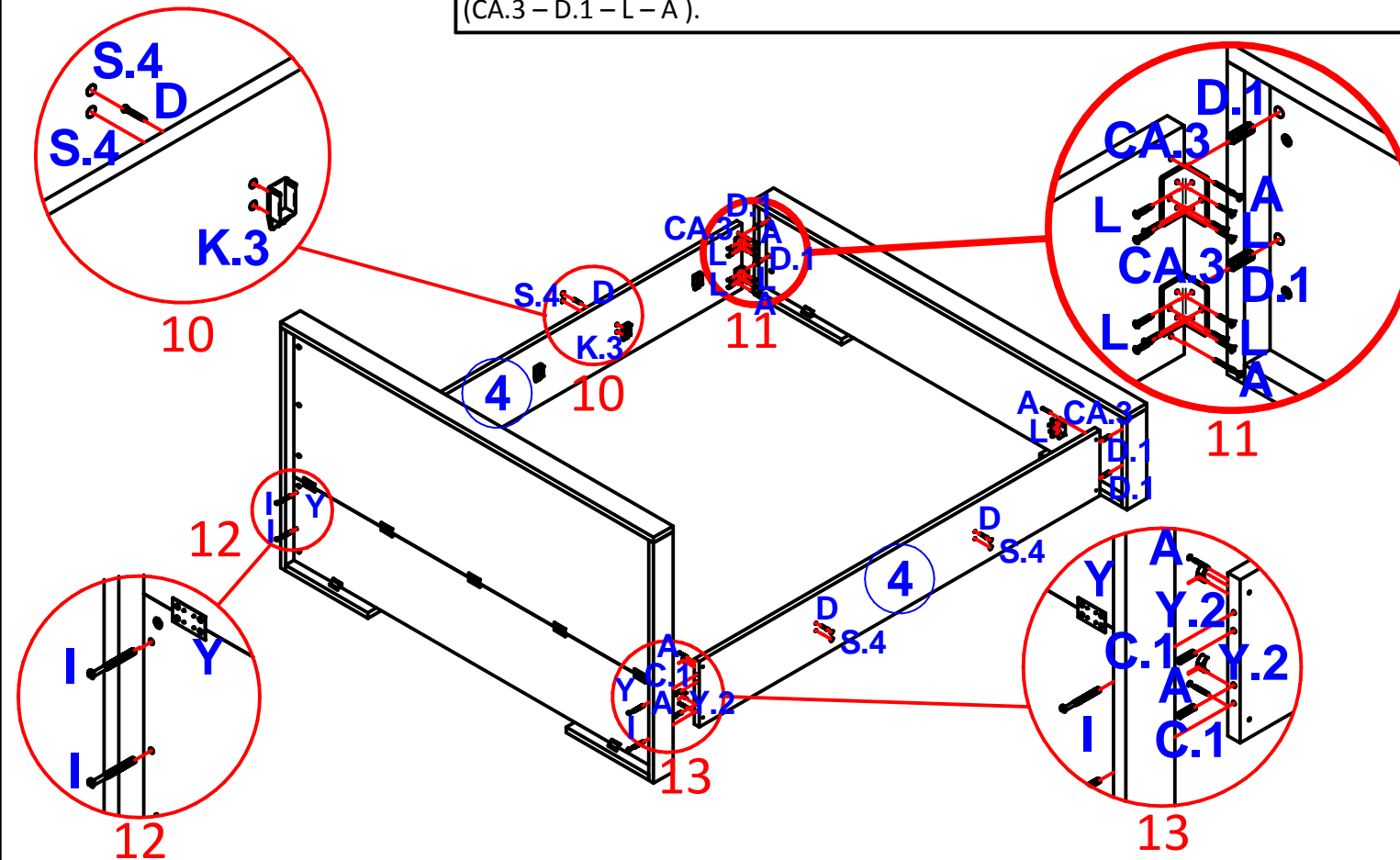

**STAGE 2
FRONT FEET**

FOOTBOARD: ATTACH PART 1 TO PART 6 USING THE HARDWARE (C.1 – R – S). ATTACH PART 8 TO PARTS 1 AND 6, USE THE HARDWARE (C.1 – Q.4 – A – T.3 - C). FINALLY, ATTACH PART 5 TO PARTS 1 AND 6, USE THE HARDWARE (C.1 - C – T.3).

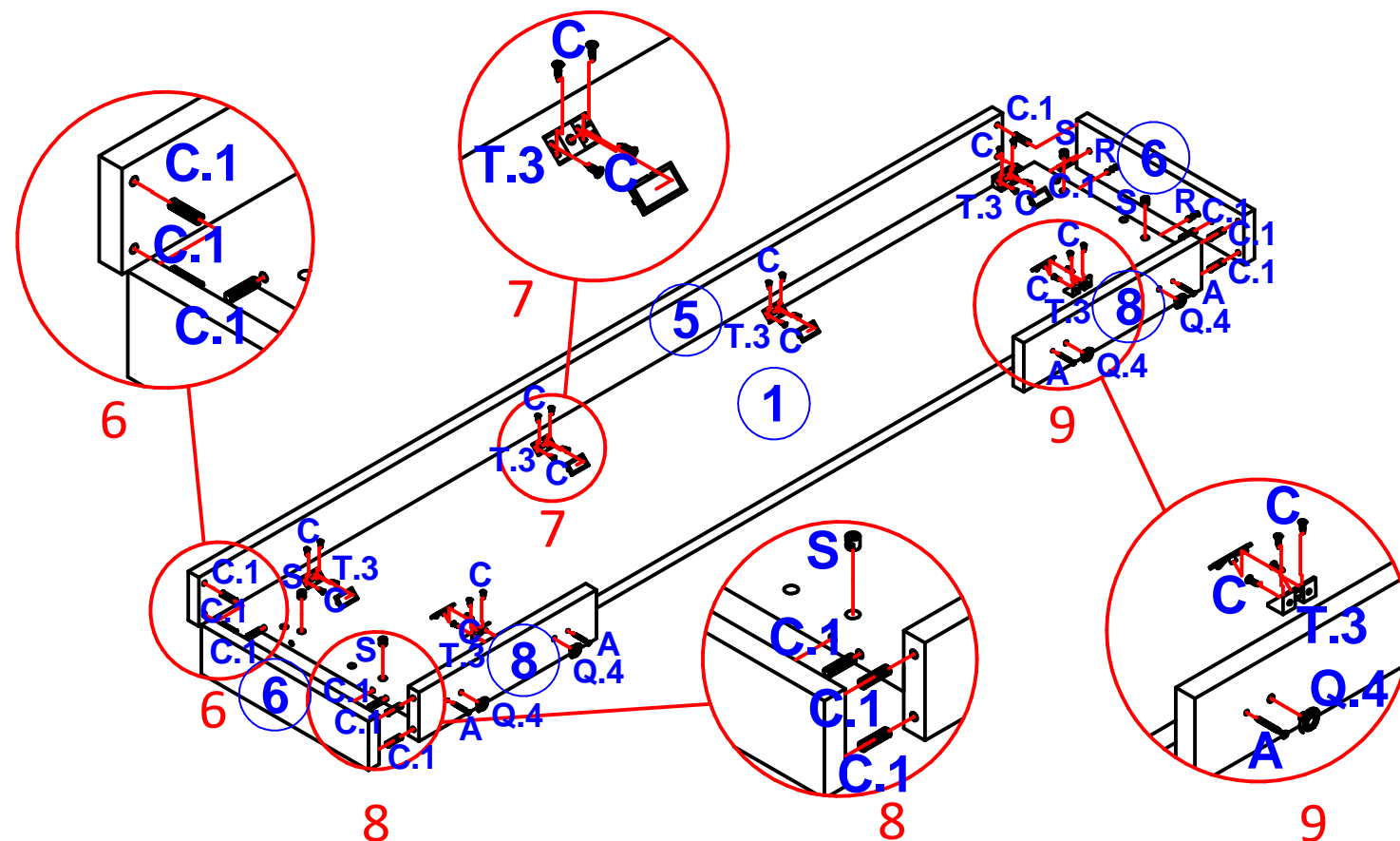

**STAGE 4
FOOT AND BALLASTS**

BED FRAME: FIRST, ATTACH THE PARTS (10) TO THE BEAMS (4) AND FIX 2 OF THEM WITH THE HARDWARE (D – S.4), NEXT ATTACH PART 9 TO PART 10 WITH SCREWS (D). FINALLY, NAIL PART 11 TO PART 10 WITH NAILS (Q.1).

